

Gurney Building Instructions

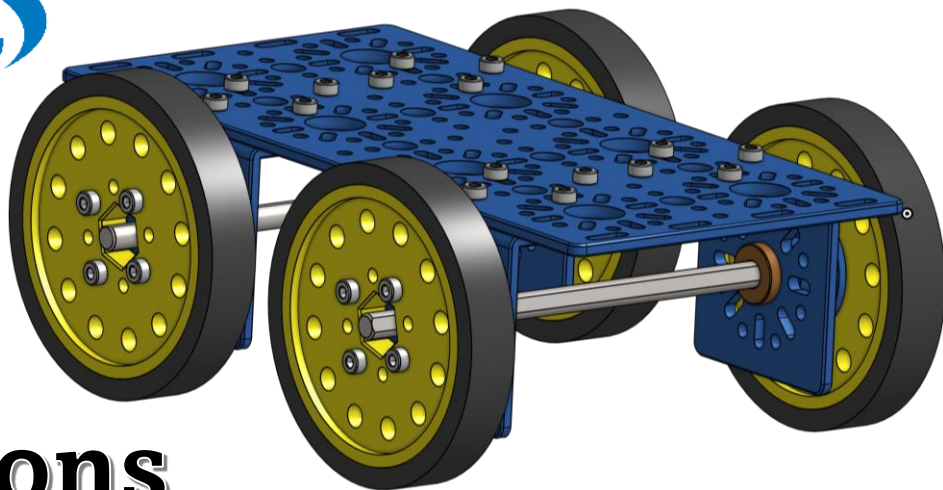

Parts Needed:

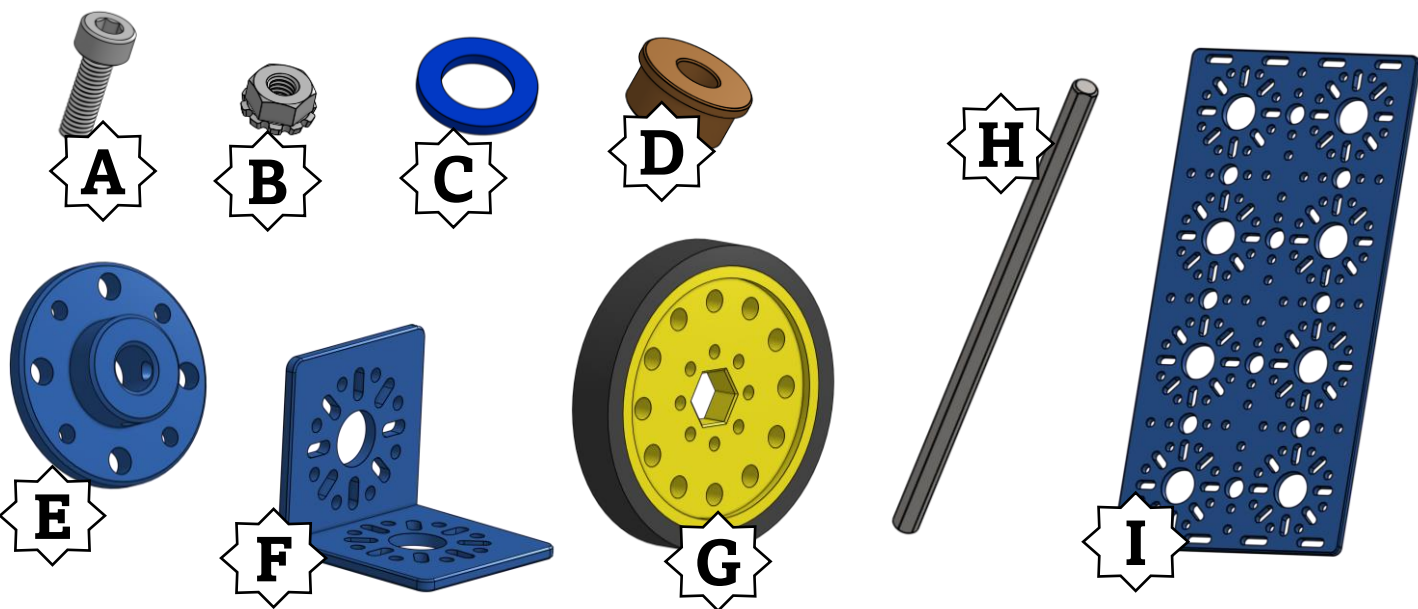

| Item | Qty | Part Number | Part Name |
|------|-----|-------------|-----------------------------------|
| A | 32 | 76201 | M3 x 10mm Socket Head Cap Screw |
| B | 16 | 76204 | M3 Kep Nut |
| C | 4 | 76305 | Shaft Spacer Plastic 1mm |
| D | 4 | 76301 | Bushings, Bronze 6mm ID x 14mm OD |
| E | 4 | 76284 | Shaft Hub 6mm |
| F | 4 | 76087 | L Bracket |
| G | 4 | 76271 | 75mm Drive Wheel |
| H | 2 | 76164 | 6mm x 140mm D- Shaft |

Procedure:

Step 1:

Using four items, "A" fasten items "E" and "G" together. Line up the 2.5mm diameter holes of the shaft hub with the 3.5mm holes of the wheel. Ensure the screw head is touching the internal wheel. Repeat for all for wheel assemblies.

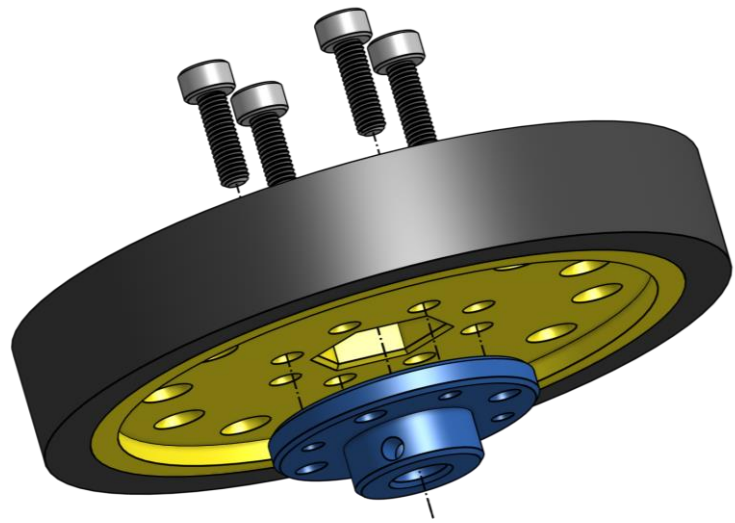

Step 2:

Using Item "I" as the base of the Gurney, mount the first L-Bracket (Item F) using four "A" and four "B." The bracket will face the outside of the flat plate. Ensure the L-Bracket's 14mm hole (big hole) is lined up perfectly with the flat brackets 8mm hole (small hole). The head of the screw will be touching the flat bracket; meanwhile, the nut will be touching the L-Bracket.

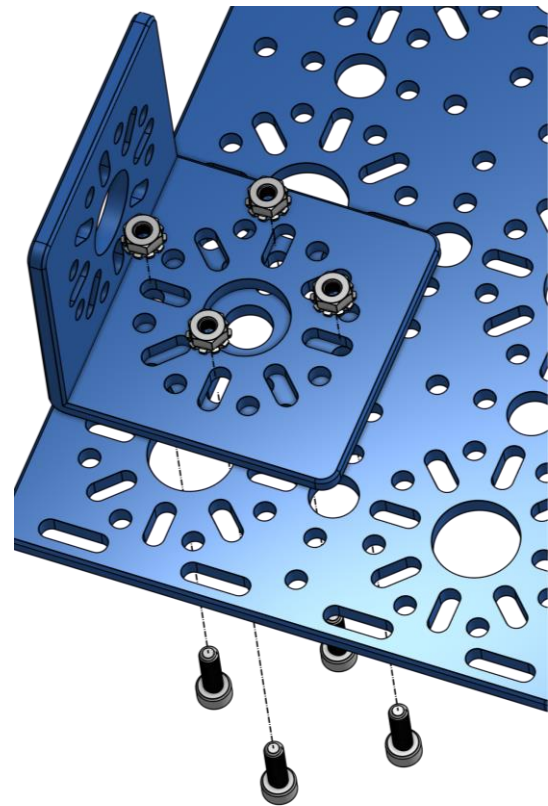

Step 3:

Repeat step 2 for the other three L – Brackets. There should be a 48mm gap between the two L-Brackets on the same side and ensure the L brackets on opposite sides are touching.

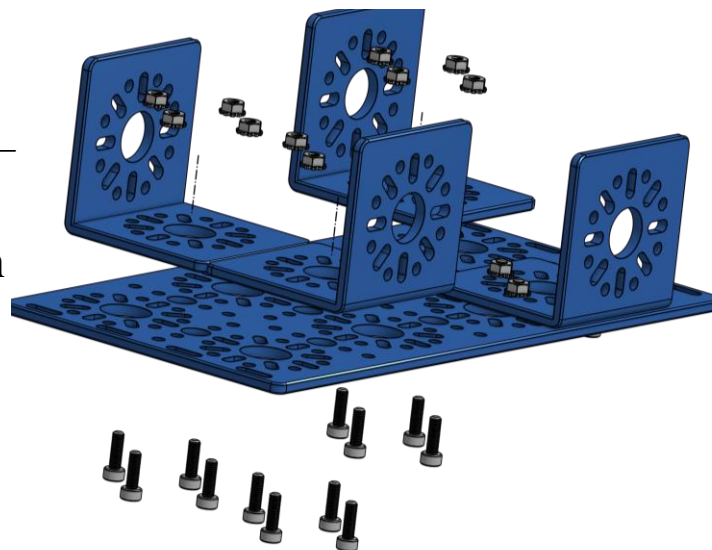

Step 4:

Using Items (C,D,H and the wheel assembly from earlier, you can create the first wheel axle. The flanged part of the bushing should sit right in the vertical 14mm hole of the L-Bracket followed by the 1mm spacer and then the wheel assembly with the hub facing the inside. The same goes for the other side.

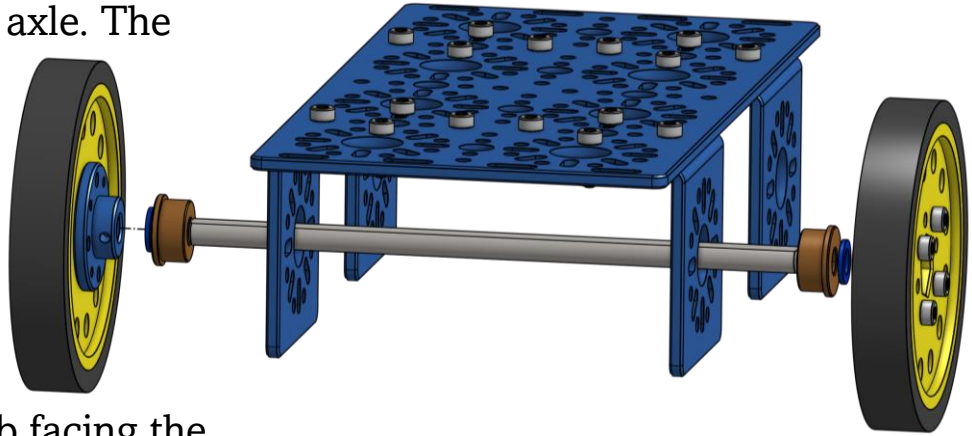

Step 5:

Using the set screws that come with the shaft hub, tighten the shaft hub onto the D- Shaft so that the D-Shaft is spaced equally on both sides. Warning: Do not squeeze the parts too tight on the axle because the wheels will be too stiff to drive. Do this with both hubs so that the axle is firm, and no parts are loose. Other Parts are hidden in image.

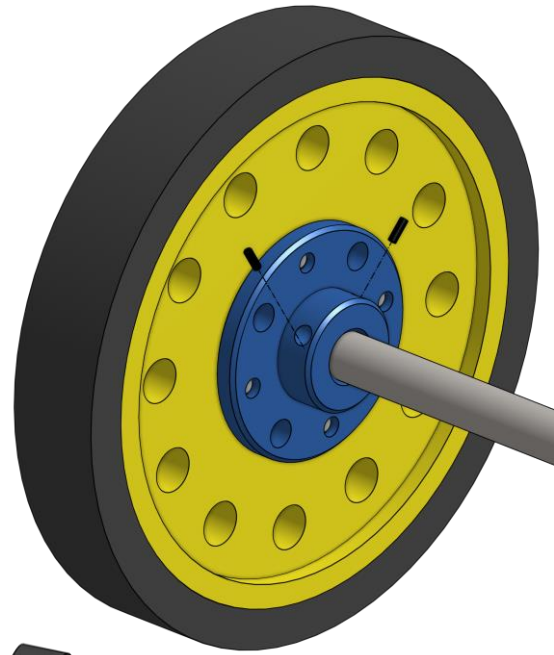

Step 6:

Repeat steps 4 and 5 for the axle on the other side, which should go through the other two L-Brackets. Once both steps are done, ensure that the wheels are rotating with ease. If not, loosen the set screw and allow for room between the hub and the spacer. Once the wheels are moving fine, you are all done!

